

# GENERAL HYDROPONICS® WaterFarm

## Assembly Guide



- ① Insert black DLT Clip (F) into Reservoir (B) as shown.
- ② Install the blue Drain Level Tube (G) into the Reservoir (B). From the outside of the reservoir, insert the elbow into the rubber grommet at the base of the reservoir. Place the top of the blue Drain Level Tube (G) through the DLT Clip (F) for support.
- ③ Place the Growing Chamber (A) inside of the Reservoir (B).
- ④ Connect the Drip Ring Assembly (H) as shown. Push the Pumping Column & Drip Ring Assembly (H) through the large hole in the Growing Chamber (A) until it nearly touches the base of the Reservoir (B).
- ⑤ Raise the Drip Ring Assembly (H) and fill the Growing Chamber (A) with rinsed Clay Pebbles (C). Securely attach the Clear Airline (E) to the Pumping Column & Drip Ring Assembly (H). Attach the other end of the Clear Airline (E) to the Air Pump (D).

①

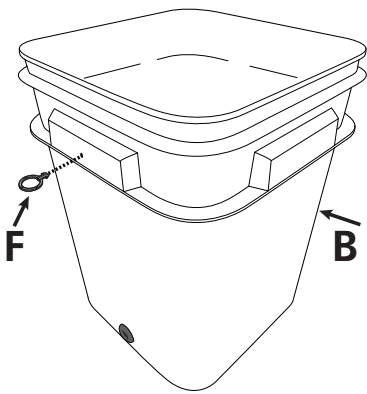

②

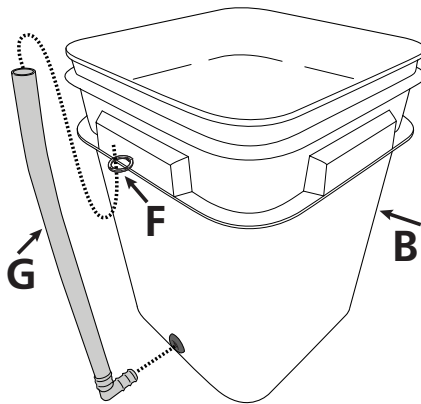

③

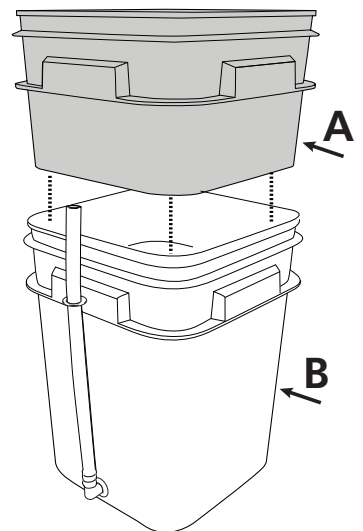

④

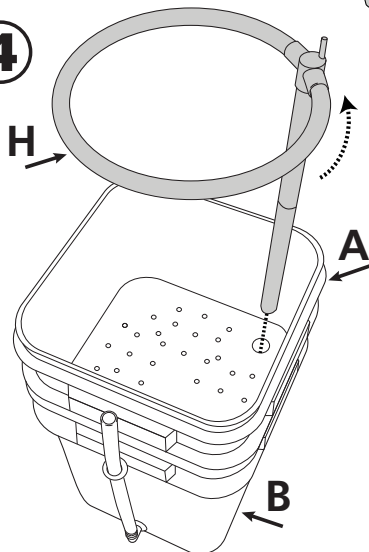

⑤

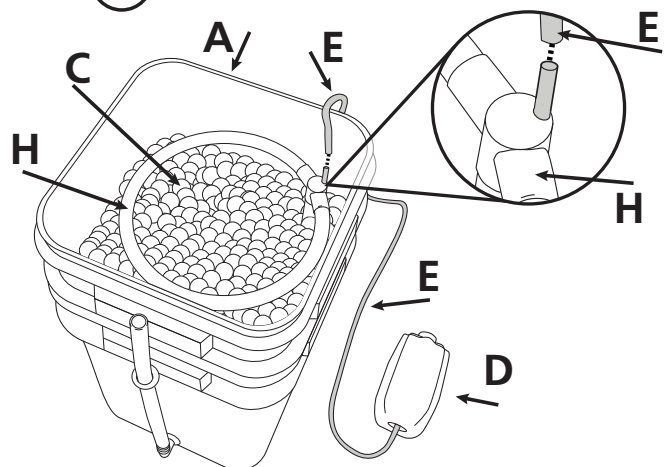

## FILLING

When filling the system with a nutrient solution it is best to mix the nutrients in a known volume of fresh water. Then pour into the WaterFarm until the water level reaches the white line on the Drain Level Tube. The system holds approximately 2 gallons of nutrient and will sustain small plants one to two weeks and may only last a few days with larger plants.

## PLANTING

**Pre-rinse the clay pebbles. This will prevent dust from clogging your system.** To prepare a seedling or a plant for transplanting, remove all soil and/or organic material from around the roots. Plants must be sturdy with established roots before transplanting into the WaterFarm. Choose seedlings because it's more difficult to successfully transplant older plants. If your plant has been growing in soil or peat moss, gently remove the plant from its pot and carefully rinse as much soil as possible from the roots before transplanting. Although this method of transplanting from soil to hydroponics is somewhat risky, as soil may contain disease organisms that proliferate in the rich hydroponic solution, we have had success using this transplant method and encourage you to try it. You can avoid these problems by starting plants from cuttings in one of our RainForest Systems.

## PLACEMENT

Abundant light, proper temperature and adequate ventilation are crucial for fast growth, healthy plants and higher yields. Place the WaterFarm in a warm, well-lit, well-ventilated location, such as an outdoor garden, sunlit window, patio or greenhouse. Keep your WaterFarm away from areas where the inevitable dripping that occurs during filling, draining and pH adjustment could cause water damage.

*If you plan to grow several small plants in the WaterFarm, place your plants just outside the drip ring, near the drip holes. If you prefer a single large plant, place it in the center of the drip ring. Gently add Clay Pebbles around the plant roots until thoroughly covered.*

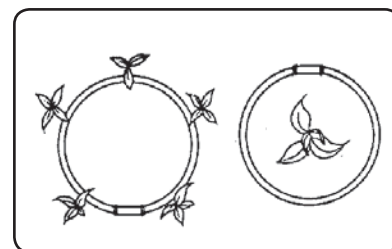
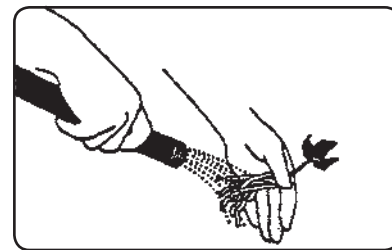
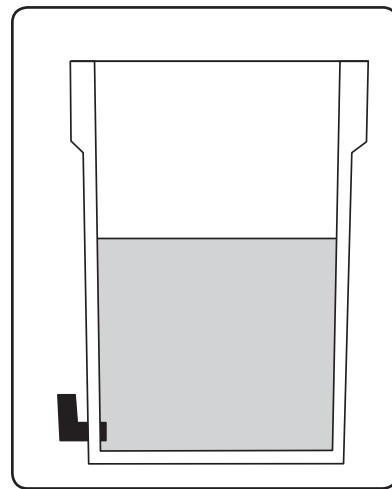

## TROUBLE SHOOTING

### If white salt deposits form on the clay pebbles:

1. Try using a milder nutrient solution and topping off with plain water only.
2. Occasionally drain your system, refill with plain water and run the pump overnight. After the overnight rinse, empty reservoir and refill with fresh nutrient.

### If plants are not growing well and you suspect "hard" water:

1. Use FloraMicro Hardwater in place of FloraMicro.
2. Try distilled or purified water. You should see a significant improvement in plant health and growth within one week.
3. Collect rainwater for use in your WaterFarm.

### If nutrient solution stops flowing from the drip ring:

1. Check to ensure that pump is plugged in and reservoir is filled with nutrient solution.
2. Disconnect air line from the air inlet and check whether the air is coming through (put end under water and look for bubbles if you are not sure). No air flow could mean that the pump is broken and must be replaced or that the air line is loose or blocked. Try cutting an inch off each end of the line to provide a tighter fit.
3. Blow into the air inlet to check whether it is clogged, and rinse the pumping column in hot water. This type of clogging is usually an indication that you have hard water or too strong a nutrient solution.
4. Check whether emitter holes in the drip ring are clogged. To clear, dis-assemble drip ring by pulling it apart at the tee, rinse drip ring and tee in hot water and clear the holes with a toothpick.